



VACUUM PACKING MACHINE

Vakuumverpackungsmaschine

PP-3.3



ISO 9001
BUREAU VERITAS
Certification



CE

PP-3.3

VACUUM PACKING MACHINE Vakuumverpackungsmaschine

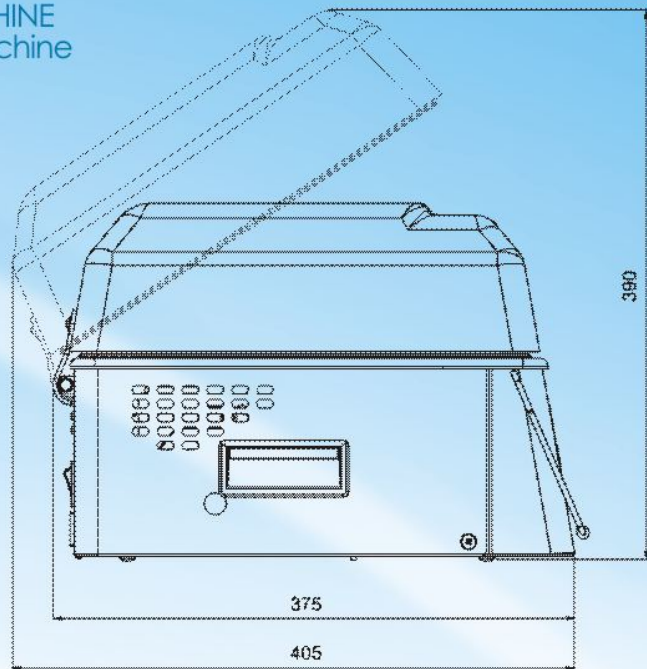
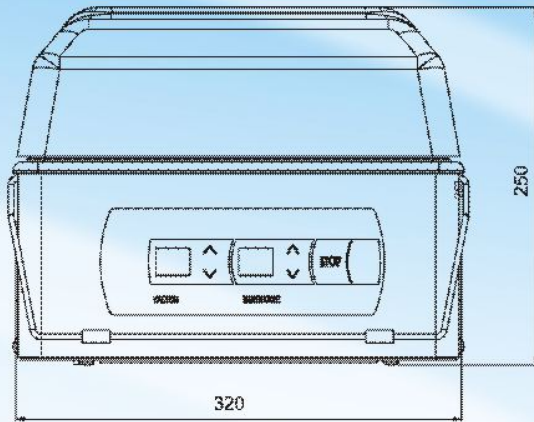

TYPE OF SEALING BAR

Art der Siegelleiste

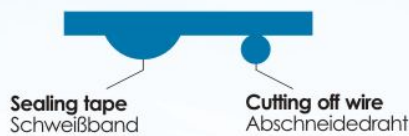

POSITION OF SEALING BAR

Position der Siegelleiste

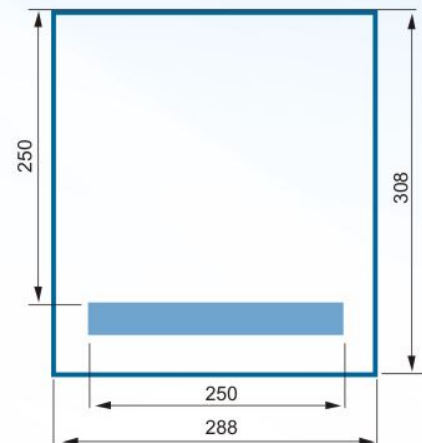

TECHNICAL DATA TECHNISCHE DATEN		PP-3.3
Chamber dimensions Kammerabmessungen	mm MM	288 x 308 x 86
Length of sealing bar Länge der Siegelleiste	mm MM	250
Length of seal Schweißlänge	mm MM	240
Vacuum pump capacity Kapazität der Vakuumpumpe	m ³ /h M ³ /h	4
Overall dimensions Maschinenmaße	mm MM	320 x 375 x 250
Weight Gewicht	kg Kg	23
Power supply Stromversorgung	V/Hz B/Hz	230/50
Power rating Leistung	kW kW	0,1
Type of sealing bar Art der Siegelleiste	seal + cutting off Schweißen + Abschneiden	



ZAKŁAD TECHNIKI PRÓŻNIOWEJ

TEPRO SA

75-216 Koszalin
ul. Przemysłowa 5
tel. +48 94 343 24 81
fax +48 94 343 26 58
www.tepro.com.pl
marketing@tepro.com.pl

