

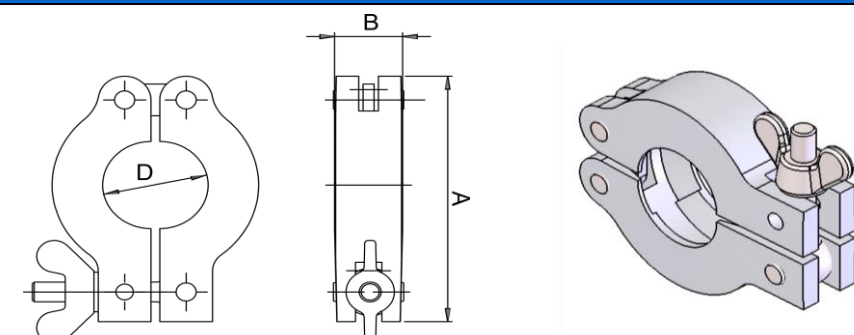

ARMATURA PRÓŻNIOWA

1/6

Rodzaj armatury	Symbol		A	B	C	D	E	Rysunek
	indeks wyrobu	wg AP-0.00	mm	mm	mm	mm	mm	
Pierścień sprzęgający złącza zaciskowego (zapinacz)	KA16	DN10-16	60,5	16	-	22	-	
	KA25	DN20-25	72,5	16	-	30	-	
	KA40	DN32-40	90	16	-	46	-	
Kołnierz dociskowy	KY16	DN16	60	45	20,2	6,6	8	
	KY25	DN25	70	55	28,3	6,6	8	
	KY40	DN40	100	60	45	9	10	
Pierścień centrujący	KH16	DN16	17	15	18,5	-	-	
	KH25	DN25	26	24	28,5	-	-	
	KH40	DN40	41	39	43	-	-	

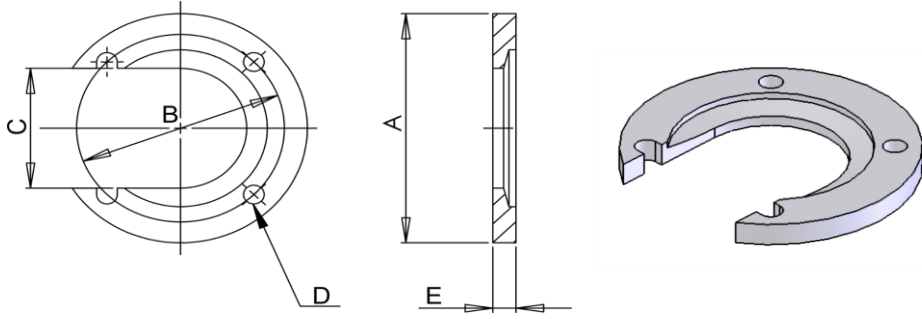
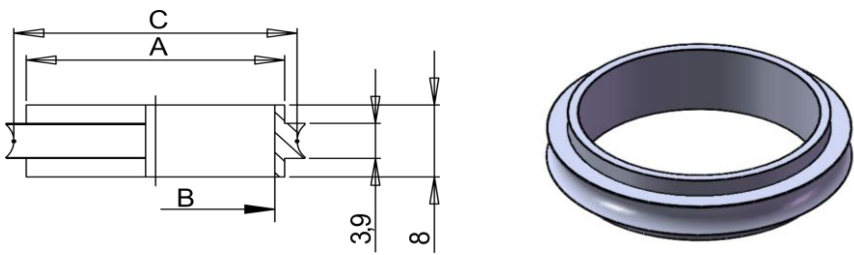

ARMATURA PRÓŻNIOWA

2/6

Rodzaj armatury	Symbol		A	B	C	D	E	Rysunek
	indeks wyrobu	wg AP-0.00	mm	mm	mm	mm	mm	
Pierścień centrujący redukcyjny	KH10-16	DN10-16	17	10	12	18,5	-	
	KH20-25	DN20-25	26	21	22	28,5	-	
	KH32-40	DN32-40	41	32	34	43	-	
Pierścień uszczelniający	KG16	DN16	18	-	-	-	-	
	KG25	DN25	28	-	-	-	-	
	KG40	DN40	42	-	-	-	-	
Końcówka KZ16-40	KZ16	DN16	25	16	20	-	-	
	KZ25	DN25	30	24	28	-	-	
	KZ40	DN40	30	40	44,5	-	-	



ARMATURA PRÓŻNIOWA

3/6

Rodzaj armatury	Symbol		A	B	C	D	E	Rysunek
	indeks wyrobu	wg AP-0.00	mm	mm	mm	mm	mm	
Końcówka do węża	AP16Z-50-01	DN16	17	14	40	-	-	
	AP25Z-50-01	DN25	28	23	45	-	-	
	AP40Z-50-01	DN40	43	38	55	-	-	
Zaślepka 16-40	KX16	DN16	5	-	-	-	-	
	KX25	DN25	5	-	-	-	-	
	KX40	DN40	5	-	-	-	-	
Łącznik	AP16Z-3-01	DN16	80	16	-	-	-	
	AP25Z-3-01	DN25	100	24	-	-	-	
	AP40Z-3-01	DN40	130	40	-	-	-	



ARMATURA PRÓŻNIOWA

4/6

Rodzaj armatury	Symbol		A	B	C	D	E	Rysunek
	indeks wyrobu	wg AP-0.00	mm	mm	mm	mm	mm	
Łącznik redukcyjny	AP16Z-34-00	DN40/16	27,5	16	-	-	-	
	AP25Z-34-00	DN16/25	80	16	-	-	-	
	AP40Z-34-00	DN25/40	100	24	-	-	-	
Kolanko	AP16Z-31-00	DN16	40	16	-	-	-	
	AP25Z-31-00	DN25	50	24	-	-	-	
	AP40Z-31-00	DN40	65	40	-	-	-	
Trójnik	AP16Z-32-00	DN16	40	16	80	-	-	
	AP25Z-32-00	DN25	50	24	100	-	-	
	AP40Z-32-00	DN40	65	40	130	-	-	



ARMATURA PRÓŻNIOWA

5/6

Rodzaj armatury	Symbol		A	B	C	D	E	Rysunek
	indeks wyrobu	wg AP-0.00	mm	mm	mm	mm	mm	
Czwórnik	AP16Z-33-00	DN16	40	16	80	-	-	
	AP25Z-33-00	DN25	50	24	100	-	-	
	AP40Z-33-00	DN40	65	40	130	-	-	
Łącznik giętki 16-40	AP16Z-40-00	DN16	60	16	-	-	-	
	AP25Z-40-00	DN25	100	24	-	-	-	
	AP40Z-40-00	DN40	130	40	-	-	-	
Wąż próżniowy 16-40 z PVC	AP16Z-50-00	DN16	wg życzeń odbiorcy	16	-	-	-	
	AP25Z-50-00	DN25		24	-	-	-	
	AP40Z-50-00	DN40		40	-	-	-	



ARMATURA PRÓŻNIOWA

6/6

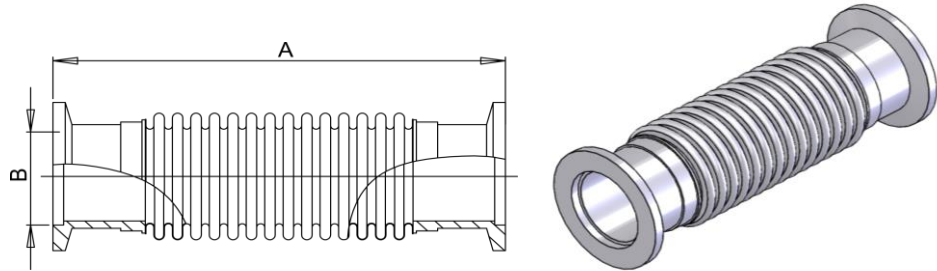
Rodzaj armatury	Symbol		A	B	C	D	E	Rysunek
	indeks wyrobu	wg AP-0.00	mm	mm	mm	mm	mm	
Wąż próżniowy 16-40 nierdzewny	AP16Z-60-00	DN16	wg życzeń odbiorcy	16	-	-	-	
	AP25Z-60-00	DN25		24	-	-	-	
	AP40Z-60-00	DN40		40	-	-	-	

Inne rodzaje armatury - na zapytanie.

www.tepro.com.pl